

Analog Multiplier Based Single Phase Power Measurement

Shweta Pandey^{1*} and Bhupal Singh²

¹Krishna Engineering College, Ghaziabad, India

²Ajay Kumar Garg Engineering College, Ghaziabad, India

Abstract

Present paper proposes a power measurement technique of a single phase electrical load. The proposed method is a low cost power measurement technique. The load which is taken into consideration is either resistive load such as bulb or inductive load like single phase induction motor. This method is based on a low cost analog IC (AD633) which does the analog multiplication of the two input signals. In fact, AD633 is well suited for applications such as power measurement, modulation and demodulation, automatic gain control, voltage-controlled amplifiers, and frequency doublers. In the present work AD633 is employed for power measurement. The AD633 output voltage give the multiplication of corresponding current and voltage signals of the load and produces pulsating signal/voltage at the double of the supply frequency. The higher frequency output of AD633 is attenuated by a low pass filter of an appropriate cut-off frequency (90 Hz). The corresponding DC component of the multiplier IC output obtained at the output of the active RC low-pass filter is found to be proportional to the average load power consumed. The output of RC low pass filter was plotted against different values of load using MATLAB code. The linearity of these plots was checked through the linear curve fit and the original plots for the validation purposes.

Keywords: Power measurement; Analog multiplication; Frequency doublers; Curve fitting

Introduction

The requirement of the load power measurements is routine in the electrical engineering labs and installations. There are equipments available that can be used to measurement these quantities. Accurate measurement of power and other AC quantities is extremely important at all levels of the electrical power system, and is of value for both for power distributors and power consumers.

The objective of this paper is to design and fabricated power measurement system of an electrical load. The loads considered in the present study are resistive load (bulb) and inductive load (single phase induction motor, 220V, 1 HP). The AD633 is a low cost multiplier comprising of a translinear core, a buried Zener reference, and a unity gain connected output amplifier with an accessible summing node. AD633 is a complete four-quadrant multiplier offered in low cost 8-lead SOIC and PDIP packages. The result is a product that is cost effective and easy to apply. No external components or expensive user calibration are required to apply this IC. Monolithic construction and laser calibration make the device stable and reliable. High (10 M Ω) input resistances make signal source loading negligible. Power supply voltages can range from ± 8 V to ± 18 V. The internal scaling voltage is generated by a stable Zener diode; which gives multiplier accuracy supply insensitive [1-3].

Analog Multiplier Based Single Phase Power Measurement System Block Diagram and Schematic Diagram

This paper presents a power measurement technique of an electrical load. The proposed method is a low cost power measurement technique. The load taken into consideration is resistive load (such as bulb) and inductive load (like single phase induction motor, 220V, 1hp). This method employs analog circuit (AD633 IC) which does the analog multiplication of the two signals: one signal transducted via current transformer and the other one transducted through the voltage transformer. The AD633 finds various applications, such as power measurement, modulation and demodulation, automatic gain control,

voltage-controlled amplifiers, and frequency doublers. In present application AD 633 is used for power measurement. The multiplication of signals corresponding current and voltage of the load results in the pulsating power at the double of the supply frequency. The higher frequency output of AD 633 is attenuated by filtering it through a low pass filter of appropriate cut-off frequency (90 Hz). The DC average component of the multiplier output obtained at the output of the active RC low- pass filter is proportional to the average load power consumed.

The block diagram of the single phase power measurement circuit is depicted in the Figure 1. The CT and the VT employed for bringing the levels of the current and voltage signals to the accepted range of the AD 633. The acceptable maximum input supply voltages of analog multiplier AD 633IC is ± 18 volts. The current transformer and potential transformer are so chosen that the maximum input to AD 633 IC is < 18 volts. $Y_1 Y_2$ is the voltage signal from the VT. A resistor of 10 k Ω with power rating of 10 W is connected at the output of CT (Figure 2) which is then fed to terminals of multiplier. Analog multiplier AD633 multiplies these signals and produces output voltage proportional to the input quantities which in turn is fed to active RC low pass filter to suppress pulsating component. The output voltage V_o of the low

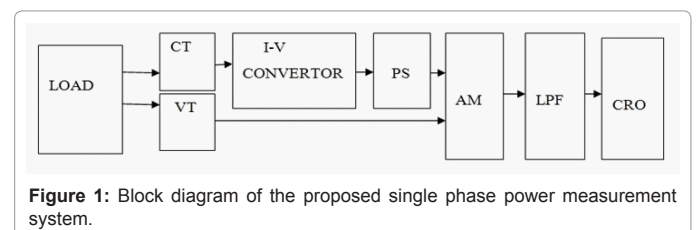

Figure 1: Block diagram of the proposed single phase power measurement system.

***Corresponding author:** Shweta Pandey, Krishna Engineering College, Ghaziabad, India, E-mail: shweta_elec@yahoo.com

Received April 23, 2012; Published May 22, 2013

Citation: Pandey S, Singh B (2013) Analog Multiplier Based Single Phase Power Measurement. 2: 700 doi:[10.4172/scientificreports.700](http://dx.doi.org/10.4172/scientificreports.700)

Copyright: © 2013 Pandey S, et al. This is an open-access article distributed under the terms of the Creative Commons Attribution License, which permits unrestricted use, distribution, and reproduction in any medium, provided the original author and source are credited.

pass filter is proportional to the average load power consumed and displayed through cathode ray oscilloscope [4-6].

Experimental Results

First case: Power measurement of resistive load

The schematic diagram with the components ratings and electrical connection is depicted in the Figure 2. This diagram is drawn using the OrCAD.

$$R_1 = .18K, R_2 = .18K \text{ and } C_1 = 10 \mu F$$

Table 1 shows the measured values at different points for the resistive load.

Second case: Power measurement of inductive load using phase shifter

In power measurement, it is necessary that the phase of secondary winding current shall be displaced by exactly 180° from that of the primary winding current. It is seen that the phase difference is different from 180° by an angle β (phase error). Thus in power measurement, owing to use of CT, secondary winding current not being 180° out of phase with the primary winding current. Thus, the angle β is compensated to make current out of phase by using a variable phase shifter prior to AD633 IC as shown in Figure 3. A resistor of 10 kΩ is connected to convert current into voltage at the output of CT. With

the help of a CRO the voltage signal across the secondary of the VT and across the secondary of the CT are compared. By changing the potentiometric probe of the phase shifter the phase difference between the signals is made zero.

Subsequently, this set up is used for measurement of inductive load and following parameter is recorded as given below in Table 2.

Curve fitting with Matlab

Curve fitting is a useful exercise for representing a data set in a linear or polynomial term. We are performing curve fitting to establish relation between the output of filter and load. There are two such function available in MATLAB which can be used for this purpose Polyfit (Polynomial curve fitting) and Polyval (Polynomial evaluation). The Polyfit (input data, output data, order) is a function that approximates the inputs/outputs data sets in terms of polynomial of chosen order in the sense of minimum square error. "Polyval" evaluates a polynomial for a given set of x values. So, polyval actually generates a curve to fit the data based on the coefficients found using polyfit. Figure 4 and 5 shows the polyfit for resistive load and inductive load using phase shifter.

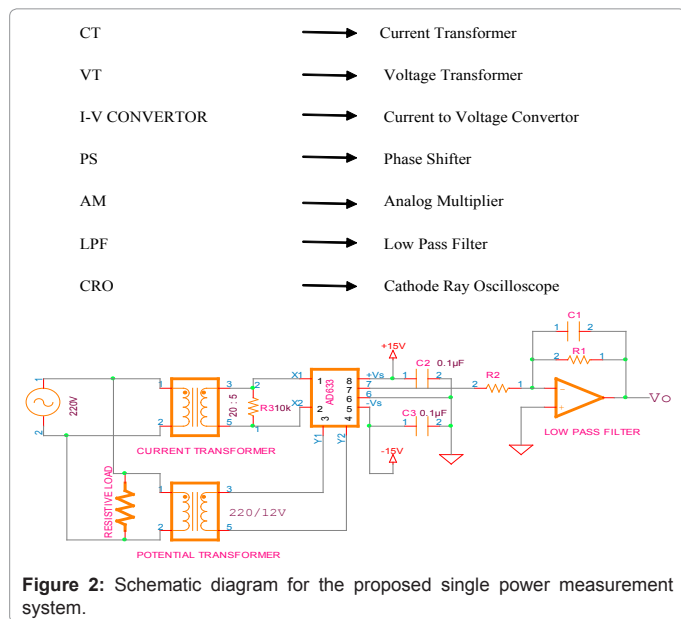

Figure 2: Schematic diagram for the proposed single power measurement system.

Resistive load (W)	CT Output voltage, V_x	PT Output voltage, V_y	Output of AD633 at pin 7	Output of low pass filter, V_o (DC)
200 W	1.9 V	12 V	2.3 V	1.5 V
300 W	3.17 V	12 V	3.8 V	2.5 V
400 W	4.10 V	12 V	4.9 V	3.3 V
460 W	4.84 V	12 V	5.8 V	3.8 V
500 W	5.38 V	12 V	6.5 V	4.3 V
560 W	6.14 V	12 V	7.4 V	4.9 V
600 W	6.41 V	12 V	7.5 V	5.2 V
625 W	6.96 V	12 V	8.5 V	5.6 V
660 W	7.25 V	12 V	8.5 V	5.8 V

Table 1: Measured dc value at the output of low pass filter for resistive load.

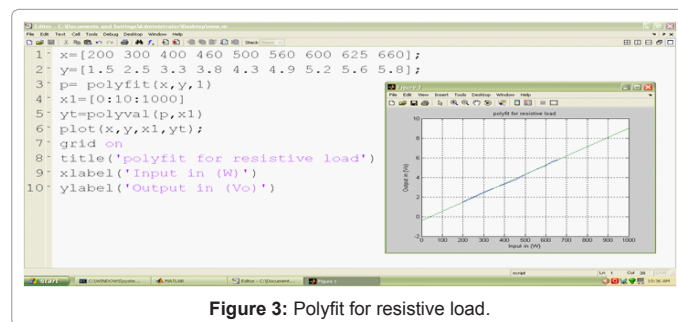

Figure 3: Polyfit for resistive load.

Inductive load (W)	CT Output voltage, V_x	PT Output voltage, V_y	Output of AD633 at pin 7	Output of low pass filter, V_o (DC)
150.0 W	7.20 V	12 V	8.6 V	5.6 V
297.8 W	7.45 V	12 V	9 V	6 V
444.0 W	8.20 V	12 V	10 V	6.4 V
587.5 W	8.62 V	12 V	10.6 V	6.8 V
678.0 W	9.16 V	12 V	11 V	7.2 V
744.5 W	10.10 V	12 V	12.2 V	7.6 V
600 W	6.41 V	12 V	7.5 V	5.2 V
625 W	6.96 V	12 V	8.5 V	5.6 V
660 W	7.25 V	12 V	8.5 V	5.8 V

Table 2: Measured dc value at the output of low pass filter for inductive load.

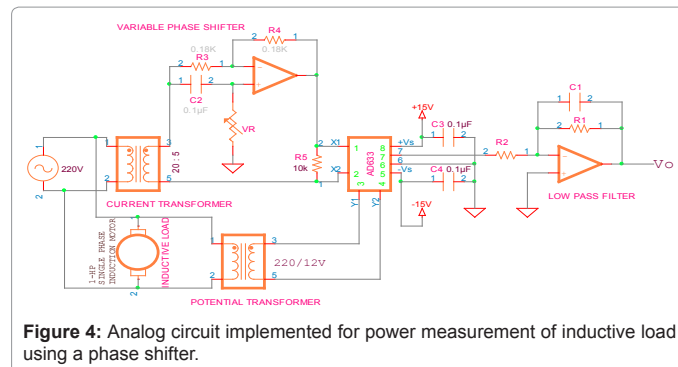

Figure 4: Analog circuit implemented for power measurement of inductive load using a phase shifter.

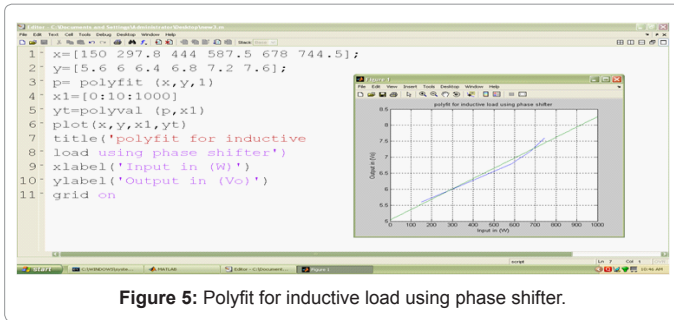

Figure 5: Polyfit for inductive load using phase shifter.

Here x are the different load values and y is their corresponding output at low pass filter.

The blue line is original plot and the green line is the polyfit plot

The equation of a line is $y = mx + c$

$$V_0 = \alpha W + c$$

$$\alpha = 0.0094 \text{ and } c = -0.4034$$

$$W = \frac{V_0 + .4034}{0.0094}$$

$$W = 106.38V_0 + 42.914$$

By putting the value of V_0 the value of W (Load power) can be known.

The blue line is original plot and the green line is the polyfit plot.

$$V_0 = \alpha W + c$$

$$\alpha = 0.032 \text{ and } c = 5.0407$$

$$W = 31.5V_0 - 157.52$$

Thus for the inductive load we obtain the relationship between load and output of filter which can be used to compute the wattage. Still it seems that there is some nonlinearity. It may be due to indirect measurement of power consumed by load; instead it should have been using the wattmeter.

Conclusion and Future Scope

In this project, it has been established the relationship of dc resistive load and ac inductive load through a linear approximation. However, the setup is not tested for capacitive load. The linearity as seen from the plot in the range of interest shows that set up can be employed for power measurement. Further same set up can be use in conjunction with the DSP or Microcontroller and can be used for other supply parameter estimation specially the supply frequency, energy consumed and power factor that too using a single measurement, that may be the part of future work and scope.

References

1. Salivahanan S, Bhaaskaran VSK (2008) Linear Integrated Circuits. Analog multipliers, Tata McGraw-Hill, New Delhi, India.
2. <http://www.utdallas.edu/~kamran/AD633.pdf>
3. Wijngaards DDL, Wolffenbuttel RF (2001) IC fabrication-compatible processing for instrumentation and measurement applications. IEEE T Instrum Meas 50: 1475-1484.
4. Sawhney AK, Sawhney P (2003) Electrical and electronics measurements and measuring instruments. Measurement and Measurement Systems.
5. Artigas JI, Urriza I, Acero J, Barragán LA, Navarro D, et al. (2009) Power Measurement by Output-Current Integration in Series Resonant Inverters. IEEE T Ind Electron 56: 559-567.
6. Simpson RH (1998) Instrumentation, measurement techniques, and analytical tools in power quality studies. IEEE T Ind Appl 34: 534-548.