

Bioremediation with the Help of Analytical Tool-Biosensors

Prantik Mukherjee*

School of Bioscience and Technology, Vellore Institute of Technology, Vellore-632014, Tamil Nadu, India

Abstract

Biosensors are nowadays are of great use in the biological fields which is an analytical tool to detect the molecule of our interest. In this paper, biosensor is used to detect the level of pollutants, nitrogen, phosphorous, dissolved oxygen and toxic compounds in a particular habitat with the help of biosensor which is used for the bioremediation of these unwanted compounds. For this, a promoter selected from a genetic operon acts as a biosensor to detect the target molecule and helps to generate the signal. Some reporter systems are also used. This is of great use in the bioremediation process and further research can be made so that the biological recognition element can be brought into close proximity to the target molecules for the integration with the signal analysis systems.

Keywords: Biosensor; Lux; GFP; Promoter; Bioremediation

Introduction

Biological sciences have been used in different fields nowadays. In the biotechnological fields, biosensors have been emerged as a great tool for the biologists as well as the computer engineers, which have created a revolution. Biosensors are generally used for the analysis of the biological outputs to monitor processes. The microelectronic elements are used to pick up the signals generated and it is processed by a number of microprocessors. The biosensors must be specific to interact with the target molecule and the biomolecules, used as biosensors is designed in such a way that it can be case specific. For this, sometimes the application of genetic engineering is needed. The second most important analytical device needed is a signal generating surface which has the potential to carry the information to a signal-processing unit. It is worth mentioning that the biosensor must be stable and flexible. Sometimes the flexibility is induced at the advent of genetic engineering [1-6].

Application to biosensor of biochemical potential

The most important aspect to yield a signal is the use of a bio-active compound that is designed in the way that can be monitored properly. There are various biological components that can be used as a biosensor like cell, cell components based on the specificity. The whole cell is generally used for the expression of recombinant protein and the reaction is catalysed through it. Nowadays, explorations have been made extensively for the use of enzyme as a biosensor. The signal generation is quite good due to the enzyme-substrate specificity and the signal is generated in different ways- may be by the product formation, reduction or disappearance of substrate, coenzyme conversion, superimposition of the reactions with other biochemical event like the use of inhibition kinetics. For example, the enzyme cholinesterase and choline oxidase is used for the detection of organophosphorous pesticides. As bioremediation is nothing but the ability of the microbes to transform the complex organic molecules into simpler forms, some of the criteria have to be maintained for the designing of the biosensor. First, it should not interfere with the microbial community of the specific region. Secondly, it should not interfere with the environmental conditions while the specificity of monitoring towards the target molecule is concerned. Thirdly, the biosensor used must not be toxic itself to the environment. This article mainly deals with the designing of biosensor based on the expression system of luciferase driven via specific promoters (Figure 1) [7-12].

The molecular biosensors

Here, a recombinant plasmid which is the biological component acts as the molecular biosensor. The plasmid is engineered in such a way that it can act as a biosensor. This biosensor has the specificity to the target molecule and its expression depends upon the presence of that target molecules. It uses the reporter system to generate the signal and the promoter can be turned on or off with specific molecules as our own need. The signal generation is directly proportional to the promoter expression. Another thing is that is the choice of the host for the expression of the promoter genes as well as the survival and multiplication of the above mentioned designed sensing molecule. The laboratory strains of *Escherichia coli* can be used but as it is not the natural inhabitants of the soil, nowadays *Pseudomonas* can be used to monitor the process of bioremediation of some compounds.

Reporter Systems

The reporter system is used to generate the signal. The reporter system actually codes for a protein(s) and it is a part of an expression vector. It has got some special properties and has the potential to catalyse some biochemical reactions for the generation of the signals. Some of the reporter systems used has been mentioned [13-20].

Bacterial luciferase reporter system

Bioluminescence is phenomenon that occurs due to the enzymatic response of luciferase activity. The experimental studies show that the same system could emit light of different wavelengths when they are used in different organisms. The series of reactions leading to emission of light are coded through the *lux* operon. The *lux* operon (*lux* CDABE) has been cloned from *Vibrio fischeri*, *Photobacterium luminescens* and others. The reaction uses the product of *lux*AB to code for luciferase activity which oxidises reduced flavin mononucleotide in the presence of molecular oxygen to generate a 4a-peroxyflavin. The resultant complex is coupled with an oxidation of long chain aliphatic

*Corresponding author: Prantik Mukherjee, School of Bioscience and Technology, Vellore Institute of Technology, Vellore-632014, Tamil Nadu, India, E-mail: mukherjee_prantik@yahoo.co.in

Received December 27, 2014; Accepted April 28, 2015; Published April 30, 2015

Citation: Mukherjee P (2015) Bioremediation with the Help of Analytical Tool-Biosensors. J Bioremed Biodeg 6: 292. doi:10.4172/2155-6199.1000292

Copyright: © 2015 Mukherjee P. This is an open-access article distributed under the terms of the Creative Commons Attribution License, which permits unrestricted use, distribution, and reproduction in any medium, provided the original author and source are credited.

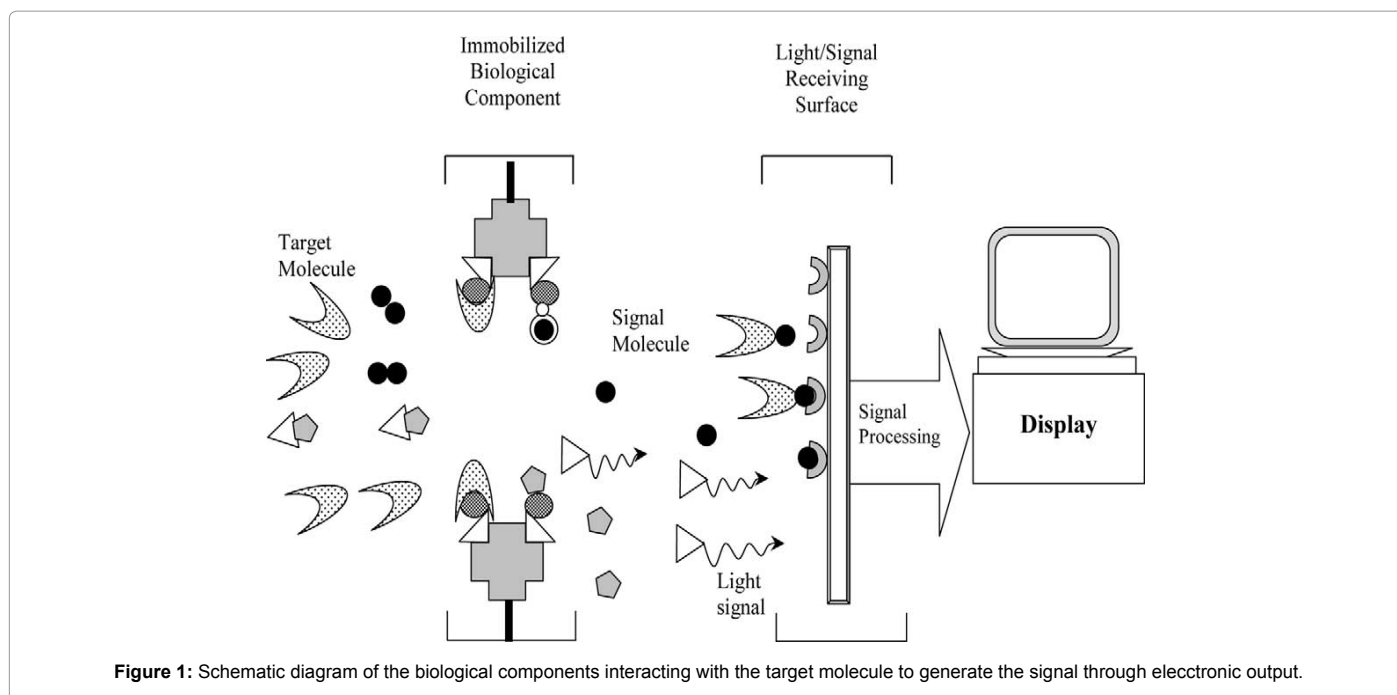

Figure 1: Schematic diagram of the biological components interacting with the target molecule to generate the signal through electronic output.

aldehyde such as n-decanal, which is generated by a fatty acid reductase complex and coded by *luxCDE* genes. The gene product of *luxAB* is sufficient to generate the light signal if a long chain aliphatic aldehyde is directly provided in the reaction at a concentration of 0.001% and based on this property, the truncated expression vector with *luxAB* has been designed. It is really helpful for the detection of diversified target molecules like presence of oxygen in the medium, xenobiotics, etc.

Green fluorescent protein

The green fluorescent protein or (GFP) also can be used as a reporter system based on the fact that the GFP of *Aequorea victoria* absorbs light with an extinction maximum of 395 nm, and fluoresces with emission maximum at 510 nm. It is worth mentioning that GFP emits bright green light of wavelength 510 nm when it is excited with ultraviolet or blue light of wavelength 395 nm.

Promoters as Biosensors

Promoters are the 5'-flanking sequence in a gene or operon which plays an important role in the DNA transcription. RNA POLYMERASE binds to specific promoters and carries out the transcription process which is also responsible for gene expression. Promoters can either take the response of a target molecule or the target molecule itself can interact with the promoters via a receptor system. Thus, for designing a biological biosensor, the promoter sequence, which is made artificially, can be placed at the 5' region of the reporter system and the selection of the promoter is based on the target molecule to be mentioned in the sample. Thus, it can be said that the promoter is the actual sensing component of a biosensor. As mentioned earlier, these kinds of biosensors have three main components- The vehicle or the vector molecule (plasmid) which helps in the maintenance of the biosensor in the particular host; next is the promoter which is the actual sensing component of the biosensor and the reporter system which could be *lux* operon, GFP or any other signal producing molecule.

The stress promoters

Some strains of bacteria synthesize a kind of protein called HEAT

SHOCK PROTEINS (HSP). These are mainly stress induced proteins which is produced when the organism face an adverse environmental situation like nutrient starvation, exposure to toxic materials, heavy metals, etc. and this protein helps them to withstand the adverse situation. The promoters from *E.coli*, such as *uspA*, *grpE* or *dnaK* were sub-cloned in the *lux* expression vector which is found to respond to various stresses when *E.coli* is used as a host. This particular expression system which is derived from these recombinant plasmids as biosensors has been proved to have a response time of less than 5 mins when they are exposed to different toxic molecules.

Nutrient monitoring

The approach of bioremediation requires a specific ratio of C:N:P so that the biological degradation can be encountered. Several promoters are used for monitoring of carbon, nitrogen and phosphorous. For example, *glnA* and *phoA* is used for determining the level of nitrogen and phosphorous respectively by their expression. Both of them is activated when there is limited level of nitrogen and phosphorous respectively. Again, the promoter P_{nah} promoter of *lux* system (in case of *Pseudomonas*) is used for the detection of carbon level of a particular region. Sometimes, the biosensors are introduced through the transposon system if it is observed that the recombinant plasmid is not stable in the particular host and creates problems with its survival. Bioremediation program mainly deals with the level of pollutants of a particular habitat where a bacterium uses a pollutant as a sole carbon source could find the same pollutant as toxic above a particular concentration. Thus, for this reason different bacterial strains have been used to monitor the toxicity signals when tested on phenol, heavy metals, polycyclic aromatic hydrocarbons, and others.

Metal ion and physical parameters monitoring

In *E. coli*, there is a protein called STRESS PROTEIN A which is encoded by *uspA* gene. The promoter *uspA* derived from this gene can be activated or deactivated non-specifically if the cell can be grown in some limited conditions like nutrient starvation, exposure to any toxic chemicals, and others. This particular promoter has the similarity with

the heat shock promoter *grpE* which is also derived from *E. coli*. These promoters have been used in the monitoring of the heavy metals like Cu^{2+} and Cd^{2+} under defined conditions. One of the most important facts is that many of the promoters derived from microorganisms have been used in the monitoring of mercury too, including its both forms. For example, *mer* operon derived promoters have been used extensively in the detection of mercury level, with a sensitivity of 1 mM concentration. This was engineered by transferring a *mer-lux* reporter system to a *Pseudomonas putida* strain. Again, biosensors have also been used for monitoring some physical parameters like pH, temperature, dissolved oxygen, which influence the growth of microorganisms.

Methodology

The methodology of molecular biosensors consists of two parts- first, the designing of the biosensor and second, their applications as a monitoring tool where the appropriate signal generation options are utilized. The construction of a molecular biosensor makes use of different genetic engineering steps. To conceptualize any biosensor one should have prior knowledge of the gene or genetic operon. A typical physiological response occurs due to expression of a series of genetic events in the cells, which may be the consequence of the switching on or off of a gene or an operon. Therefore, it can be said that the selected physiological response is due to a key gene or operon. In this case, the promoter of this gene could be considered as a very important tool for developing the biosensor, to target and monitor this physiological response under different conditions. Once a biosensor is developed, then the second step is capturing the generated signal and its quantification.

For a recombinant plasmid to be a molecular biosensor, it has to have a configuration as any other expression vector. It should have a reporter system with multiple cloning sites at the 5' end to sub-clone

the promoter. The multiple cloning sites are designed in a way that it does not interrupt the coding sequence for the reporter protein. The signal is generated as a response to target molecule; and its level could be determined as a function of target molecule and promoter interaction. The target promoter of the recombinant plasmid used in this article was amplified using the polymerase chain reaction. The primers used in the amplification provide the restriction digestion sites for directional sub-cloning.

Now comes the quantification of the generated signal- which is the most important step. The signal could either be directly a protein or something that acts as a functional protein to bring out the biochemical reaction. In the latter case, the exhaustion of substrate or generation of product is correlated with the signal. In the luciferase expression system, the luminescence signal could be quenched on the photographic film or by using a luminometer to quantify the signal. The signal captured on the photographic plate can be analysed by the densitometric analysis. The light signal generated in the luciferase system also can be received through the fiber optic device, which is connected to a data processing unit to digitize the signal, so that it can be processed quantitatively. In case of GFP, the protein is synthesized and to generate the signal, it has to be excited with a specific wavelength to produce the fluorescence phenomenon (Figure 2) [21-25].

Discussion

We have mentioned various types of biosensors including their applications, working principles, constructions and advantages in this paper. In addition we should point out that during the last two decades, advances in microelectromechanical systems (MEMS) have given rise to a whole new class of biosensors which involve the transduction of mechanical energy and are based on mechanical phenomena. The authors would like to mention that there are various technical

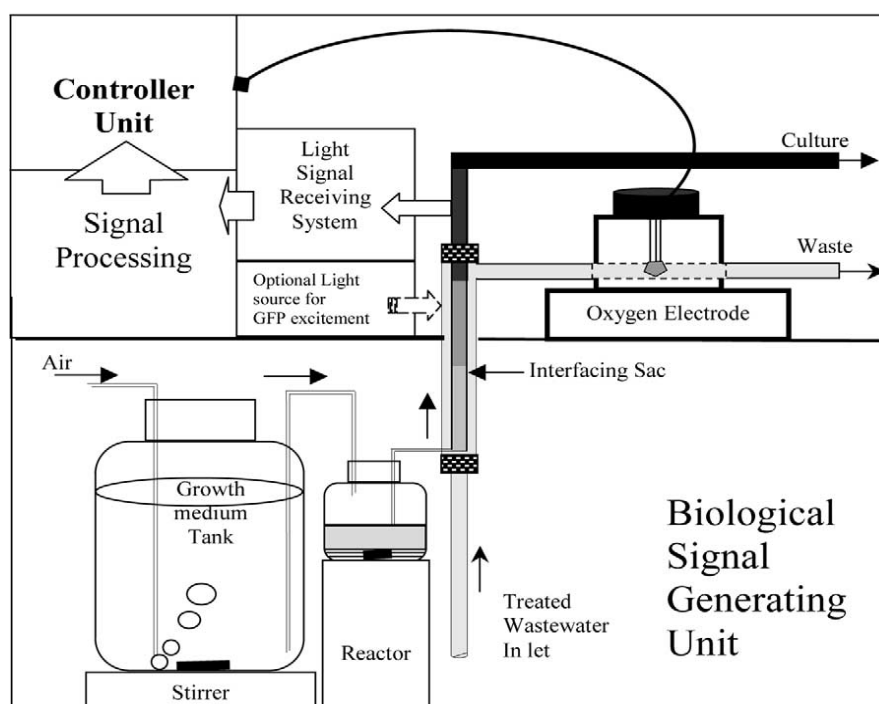

Figure 2: Schematic diagram for maintaining treatment efficiency of a biological waste water treatment system. Biological signal generating system comprises mini bioreactor having (for example) generalized stress promoter *usp::luxCDABE* for monitoring of pollutant.

difficulties for which some solutions exist, but still more research efforts are needed in order to find better alternatives. Some of them are: (a) contamination: bio elements and chemicals used in the biosensors need to be prevented from leaking out of the biosensor over time (serious issue for non-disposable ones), (b) immobilization of biomolecules: to avoid contamination, biomolecules are attached to the transducer as strongly as possible, but the problem with this is that the behaviour of enzymes when absorbed on the surface is not well understood (reaction of enzymes in free solutions is better understood), (c) sterilization: if a sterilized probe is used some sensor's biomolecules may be destroyed whereas if non-sterile probes are used some compromises are needed, (d) uniformity of biomolecule preparation: fabrication of biosensors that can reproduce results need such uniformity, (e) selectivity and detection range: should be more selective and the detection range should be large, (f) cost: research should be focused on the development of low-cost biosensors. At present, with the threat of bioterrorism omnipresent, the development of faster, reliable, accurate, portable and low-cost biosensors has become more important than ever.

References

- Gronow M, Mullen WH, Russell LJ, Anderton DJ (1988) Biosensors. In: Walker JM, Gingold EB (eds.) Molecular biology and biotechnology. pp. 323-347.
- Cass AEG (1995) Biosensors. In: Meyers RA (ed.) Molecular biology and biotechnology: a comprehensive desk reference. VCH Publishers; Cambridge, UK, pp. 110-114.
- Mulchandani A, Mulchandani P, Kaneva I, Chen W (1998) Biosensor for direct determination of organophosphorous nerve agent using recombinant *E. coli* with surface-expressed organophosphorous hydrolase. Potentiometric microbial electrode. *Anal Chem* 70: 4140-4145.
- Wang J, Kane SA, Liu J, Symth MR, Rogers K (1996) Mushroom tissue based biosensor for inhibitor monitoring. *Food Technol Biotechnol* 34: 51-55.
- Rekha K, Thakur MS, Karanth NG (2000) Biosensors for the detection of organophosphorous pesticides. *Crit Rev Biotechnol* 20: 213-235.
- Billard P, DuBow MS (1998) Bioluminescence-based assays for detection and characterization of bacteria and chemicals in clinical laboratories. *Clin Biochem* 31: 1-14.
- Hastings JW (1996) Chemistries and colors of bioluminescent reactions: a review. *Gene* 173: 5-11.
- Meighen EA (1991) Molecular biology of bacterial bioluminescence. *Microbiol Rev* 55: 123-142.
- Stewart GS, Williams P (1992) lux genes and the applications of bacterial bioluminescence. *J Gen Microbiol* 138: 1289-1300.
- Szittner R, Meighen E (1990) Nucleotide sequence, expression, and properties of luciferase coded by lux genes from a terrestrial bacterium. *J Biol Chem* 265: 16581-16587.
- Morise H, Shimomura O, Johnson FH, Winant J (1974) Intermolecular energy transfer in the bioluminescent system of *Aequorea*. *Biochemistry* 13: 2656-2662.
- Chalfie M, Tu Y, Euskirchen G, Ward WW, Prasher DC (1994) Green fluorescent protein as a marker for gene expression. *Science* 263: 802-805.
- Van Dyk TK, Majarian WR, Konstantinov KB, Young RM, Dhurjati PS, et al. (1994) Rapid and sensitive pollutant detection by induction of heat shock gene-bioluminescence gene fusions. *Appl Environ Microbiol* 60: 1414-1420.
- Van Dyk TK, Smulski DR, Reed TR, Belkin S, Vollmer AC, et al. (1995) Responses to toxicants of an *Escherichia coli* strain carrying a *uspA'::lux* genetic fusion and an *E. coli* strain carrying a *grpE'::lux* fusion are similar. *Appl Environ Microbiol* 61: 4124-4127.
- King JM, Digrazia PM, Applegate B, Burlage R, Sanseverino J, et al. (1990) Rapid, sensitive bioluminescent reporter technology for naphthalene exposure and biodegradation. *Science* 249: 778-781.
- Applegate BM, Kehrmeier SR, Sayler GS (1998) A chromosomally based *luxCDABE* whole-cell reporter for benzene, toluene, ethylbenzene, and xylene (BTEX) sensing. *Appl Environ Microbiol* 64: 2730-2735.
- Shaw LJ, Beaton Y, Glover LA, Killham K, Meharg AA (1999) Development and characterization of a *lux*-modified 2,4-dichlorophenol-degrading *Burkholderia* sp. *RASC. Environ Microbiol* 1: 393-399.
- Reid BJ, Semple KT, Macleod CJ, Weitz HJ, Paton GI (1998) Feasibility of using prokaryote biosensors to assess acute toxicity of polycyclic aromatic hydrocarbons. *FEMS Microbiol Lett* 169: 227-233.
- de Weger LA, Kuiper I, van der Bij AJ, Lugtenberg BJ (1997) Use of a *lux*-based procedure to rapidly visualize root colonisation by *Pseudomonas fluorescens* in the wheat rhizosphere. *Antonie Van Leeuwenhoek* 72: 365-372.
- Dodd CE, Stewart GS, Waites WM (1990) Biotechnology-based methods for the detection, enumeration and epidemiology of food poisoning and spoilage organisms. *Biotechnol Genet Eng Rev* 8: 1-52.
- Lyngberg OK, Stemke DJ, Schottel JL, Flickinger MC (1999) A single-use luciferase-based mercury biosensor using *Escherichia coli* HB101 immobilized in a latex copolymer film. *J Ind Microbiol Biotechnol* 23: 668-676.
- Hansen LH, Sørensen SJ (2000) Versatile biosensor vectors for detection and quantification of mercury. *FEMS Microbiol Lett* 193: 123-127.
- Sinclair GM, Paton GI, Meharg AA, Killham K (1999) *Lux*-biosensor assessment of pH effects on microbial sorption and toxicity of chlorophenols. *FEMS Microbiol Lett* 174: 273-278.
- Belkin S, Smulski DR, Vollmer AC, Van Dyk TK, LaRossa RA (1996) Oxidative stress detection with *Escherichia coli* harboring a *katG'::lux* fusion. *Appl Environ Microbiol* 62: 2252-2256.
- Rosen R, Davidov Y, LaRossa RA, Belkin S (2000) Microbial sensors of ultraviolet radiation based on *recA'::lux* fusions. *Appl Biochem Biotechnol* 89: 151-160.