

# *Pseudomonas aeruginosa* Membrane Capacitive Characteristic and Frequency Relative Power Consumptions

Auns QH Alneami\*, Eman Ghadhban Khalil and Ali Faisal A Albeldawi

Biomedical Engineering Department, Al-Nahrain University, Iraq

## Abstract

**Introduction:** Study the electrical properties of microorganisms is a great importance to control their hostile effect especially, some organisms such as *Pseudomonas aeruginosa* (PA), when infection with this type of bacteria causes high percentage of patients' mortality in hospitals. Depending on interaction differences between bacterial cell with electrical current and human cell with electrical current, bactericidal effect may be achieved. This study observed the behavior of PA when it was exposed to different frequency values of clinically safe alternative current to prove the capacitive characteristic of bacterial membrane and find difference between powers consumed by bacterial sample for each frequency value.

**Method:** PA isolates were activated by using Trypticase Soya Broth (TSB), 10 percent of  $3.24 \times 10^8$  cfu/ml of PA mixed with agarose and poured in petri dish to solidify at room temperature. Electrical current of 20 V<sub>p-p</sub> applied to the sample via movable Nichrome electrodes or built in Nickel electrodes, 2 cm apart between anode and cathode electrodes, electrical current measured and recorded during stimulation using multi-function voltmeter.

**Results:** The results proved that in general when the frequency of electrical current increased (analysis of variance (ANOVA)  $P > 0.05$ ), the current pass through PA samples increased relatively which refer to decrease in samples' impedance due to increase in frequency from 0.366 Hz and reach maximum at 40 KHz where it become constant until 60 KHz then began to reduced again until it reaches constant value at 120 KHz.

**Conclusion:** Clinically accepted electrical current values of different frequencies values interact in different manner with PA samples, and the electrical current consumption by PA affected and in general increased by increasing its frequency. This study also shows that there is different impedance values to different electrical current frequencies values which prove some part of impedance affected by frequency change which prove that PA membrane has a capacitive effect.

**Keywords:** Bacteria; *Pseudomonas aeruginosa*; Alternative current; Frequency effect; Power consumption

## Introduction

A lot of evidence indicates that electrical stimulation (ES) enhanced the wound healing process (WHP) by inhibition of bacterial growth [1]. Bacterial cells, as do all living cells, depend on physical criteria like membrane potentials [2] or their principle metabolism of a living vitality, and it is reasonable to expect that precise cellular membrane electrical potential may be damaged by the effect of an exterior electric field. It has been shown that exterior fields can impact the  $\alpha$ -helix composition [3,4] and direction [2] of membrane proteins in eukaryotic bacterial cell and the electrophoretic movability across its membrane proteins [2,5]. Electric fields can be used to impact the electro insertion of particular proteins into the membranes of bacterial cell [6,7].

The use of low power clinically safe electrical current to aid in the treatment of bacterial infections, especially for antibiotic resistance pathogenic bacterial strains such as PA is of great importance to improve patients' survival rate that infected with these bacteria. Scientist prove that human cell own capacitive impedance [8] which create an additional impedance to alternative current. This capacitive impedance also exists in bacterial cell [9]. By finding the suitable frequency to inhibit bacterial growth and avoiding human cell an opportunity will be added to conventional anti-bacterial therapeutic techniques for treatment of infected subjects.

When human body (which may contain bacteria) subjected to the passage of alternating current (AC) it acts as both R-C series and RC parallel circuits as represented in Figures 1 and 2.



Figure 1: RC series circuit.

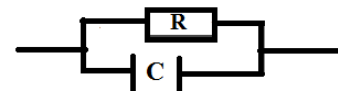

Figure 2: RC parallel circuit.

In series RC circuits the total impedance of the circuit can be calculated using the following equation

$$Z = \sqrt{R^2 + (-X^2 c)} \quad (1)$$

For the parallel RC circuits the total impedance of the circuit is calculated using the following equation

\*Corresponding author: Auns QH Alneami, Biomedical Engineering Department, Al-Nahrain University, Iraq Tel: +967901987187; E-mail: [logean1978@yahoo.com](mailto:logean1978@yahoo.com)

Received November 20, 2017; Accepted March 20, 2018; Published March 27, 2018

Citation: Alneami AQH, Khalil EG, Albeldawi AFA (2018) *Pseudomonas aeruginosa* Membrane Capacitive Characteristic and Frequency Relative Power Consumptions. J Biotechnol Biomater 8: 281. doi: [10.4172/2155-952X.1000281](https://doi.org/10.4172/2155-952X.1000281)

Copyright: © 2018 Alneami AQH, et al. This is an open-access article distributed under the terms of the Creative Commons Attribution License, which permits unrestricted use, distribution, and reproduction in any medium, provided the original author and source are credited

$$Z = \sqrt{R^2 + \frac{RX_c}{(-X^2 c)}} \quad (2)$$

The possible path of electric current as shown in Figure 3, the extracellular path represented by Resistance R2, while the intracellular path represented by the compensation of capacitor “ the outer part of the cell is cell membrane and work as a capacitor” and resistance R1. The reactance of capacitor depends on the frequency of the applied current as clarified in equation 3:

$$\text{Reactance} = X_c = \frac{1}{2\pi f c} \quad (3)$$

So there will be two paths to current to pass through, it will pass in one of them or both according to differences in resistivity and capacitive impedance.

## Materials and Methods

1. Digital Function Generator (FeelTech FY 3200S Dual channel/ made in China).
2. DC regulated power supply (OJE/QJ3005XII)
3. Digital Multimeter 1 (VICTOR VC97) China.
4. Digital Multimeter 2 (TOTAL TMT46001) China.
5. Nichrome wire electrodes.
6. Nickel electrodes (VacPac electrodes).

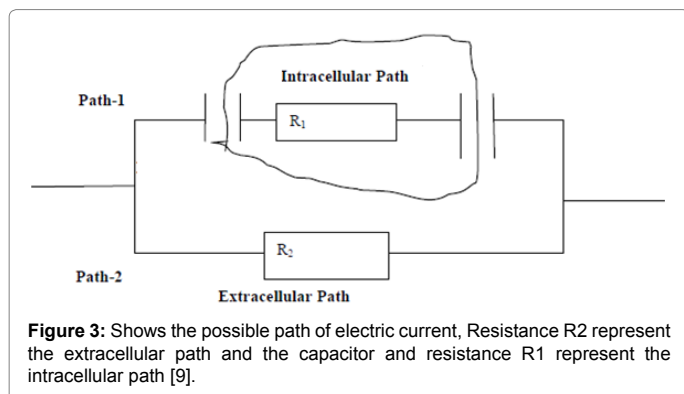

PA isolates suspension, is prepared by dissolving A 6 g of broth powder dissolved at 200 ml of distilled water (concentration 30 gm/L) in a beaker, sterilized at 121°C for 15 min, the broth cooled at room temperature, 1 ml from PA stock ( $3.24 \times 10^8$  cfu/ml) poured in the prepared broth and mixed gently manually, then the cultured broth incubated at 37°C and 200 rpm for 20-22 h using shaker incubator.

A 4.93 g of PBS (concentration of 9.86 g/L) dissolved in 500 ml of distilled water and mixed well manually, adding 1.5 g of agarose to 150 ml of the prepared PBS solution and mixed well manually, then completely dissolved and sterilized using microwave for about 140 s. After cooling to about 37°C at room temperature, 10% (i.e. 15 ml) of activated PA in TSB added to the mixture and mixed gently, finally the cultured agar poured in 60 mm diameter petri dishes and cooled at room temperature until solidification.

A function generator used to stimulate bacteria by different sine wave electrical current of frequencies from 0.366 Hz to 11 KHz using movable Nichrome gage 24 electrodes while for higher frequencies starting by 20 KHz to 120 KHz voltage stabilizer circuit with 2 mm diameter Nickel electrode were used to control voltage drop in function generator due to high frequency so at these values since a voltage stabilizer was used as shown in Figure 4, the effective voltage value considered to calculate power consumption was

$$V_{rms} = \frac{10}{\sqrt{2}} = 7.07V$$

## Results and Discussion

When 20 V<sub>pp</sub> alternative electrical current applied to bacterial samples at different frequencies from 0.366 Hz to 60 KHz it was clear that more current pass through the sample as frequency increased which refers to decrease in impedance to electrical current while the current decreased, at frequency values of 80 KHz and more until it finally reaches final constant value at 120 KHz and keep this value for higher frequencies even to 1.1 MHz. Table 1 shows the applied alternative current frequency values and their corresponding current and power consumption (Equations 4 and 5) by the sample which clarified in Figures 5 and 6.

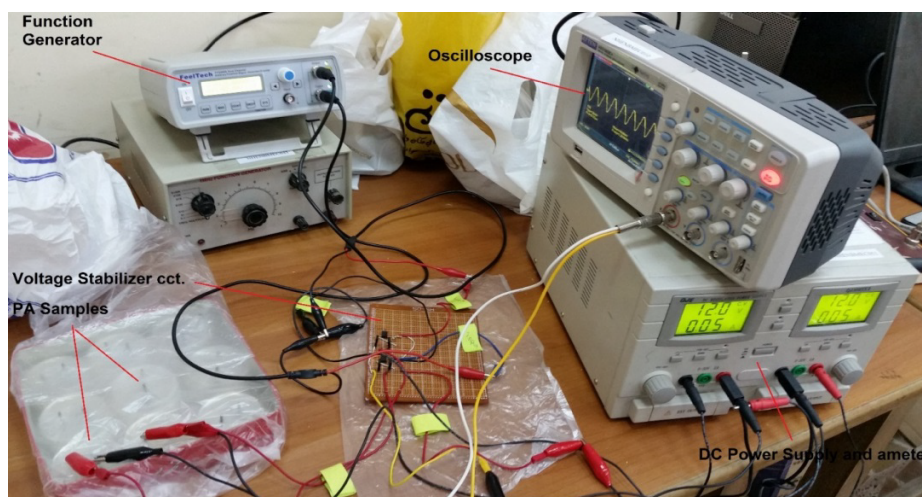

No.	Frequency (Hz)	Root mean square value of Current ( $I_{rms}$ )	Root mean square value of voltage ( $V_{rms}$ )	Power (milliwatts)
1.	0.366	0.001 mA	1.2 V	0.0012
2.	0.57	0.0044 mA	1.3 V	0.00572
3.	1	0.0046 mA	1.37 V	0.006302
4.	11	0.005 mA	1.5 V	0.0075
5.	102	0.12 mA	4.2 V	0.504
6.	202	0.12 mA	4.2 V	0.504
7.	300.8	0.12 mA	4.6 V	0.552
8.	401.5	0.12 mA	4.7 V	0.564
9.	502.4	0.25 mA	4.0 V	1
10.	11 K	4.1 mA	0.6 V	2.46
11.	20 K	40 mA	7.07 V (using voltage stabilizer)	282.8
12.	40 K	70 mA	7.07 V (using voltage stabilizer)	494.9
13.	60 K	70 mA	7.07 V (using voltage stabilizer)	494.9
14.	80 K	60 mA	7.07 V (using voltage stabilizer)	424.2
15.	100 K	60 mA	7.07 V (using voltage stabilizer)	424.2
16.	120 K	50 mA	7.07 V (using voltage stabilizer)	353.5
17.	1.1 M	50 mA	7.07 V (using voltage stabilizer)	353.5

Table 1: Current pass through PA sample and their power consumption according to frequency increments.

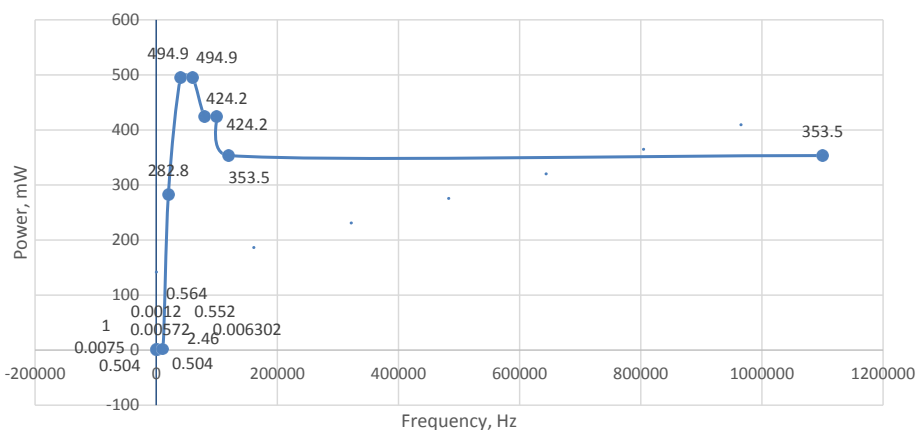

Figure 5: Relation between frequency increments and current values pass through PA sample.

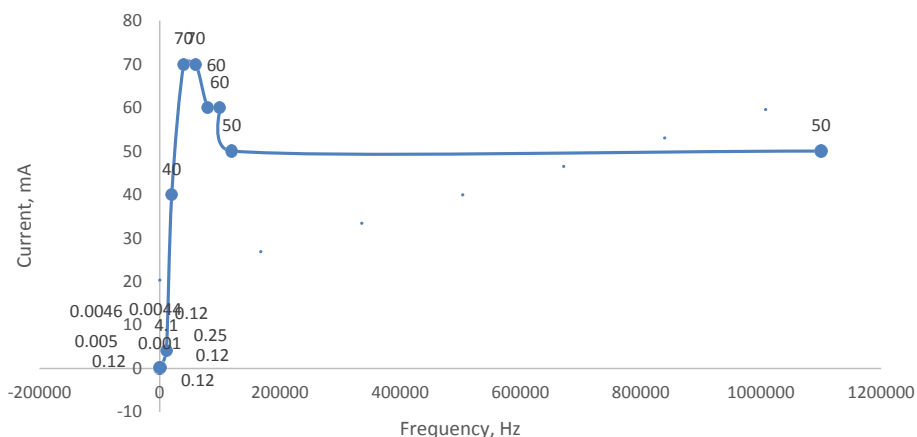

Figure 6: Relation between frequency increments and power consumption values pass through PA sample.

Where:

$$V_{rms} = \frac{V_p}{\sqrt{2}} = \frac{10}{\sqrt{2}} = 7.07V \quad (4)$$

$$P(\text{watt}) = V_{rms} \times I_{rms} \quad (5)$$

This experimental study aimed to prove the theoretical assumption that there is electrical capacitive effect caused by bacterial membrane and measure the power consumption for different AC frequencies applied on PA samples and clarify that there is a differences between samples impedance to AC according to the change in frequency value and that this impedance decreased relatively to the increase of frequency and so happened to the power consumption by bacterial samples reaching their minimum value of impedance and maximum value of power consumption at frequencies range (40-60) KHz which prove the assumption of bacterial membrane capacitive characteristic, According to electricity law in equation 6:

$$X_c = \frac{1}{2\pi fC} \quad (6)$$

Where:  $X_c$ : is the capacitive impedance in ohm ( $\Omega$ ) units, f: is the frequency in Hz, and C: is the capacitance vale in farad (F) units

But the value of impedance increased again slightly and relative to that the value of power consumption decrease also slightly until reach constant value at AC frequency value of 120 KHz and keep this value until 1.1 MHz (maximum value of AC frequency used in this work), This increment in impedance may be due to that super high frequency values add inductance effect which increase impedance (equation 7) or both extracellular and intracellular matrix began to work as one subject which increase the total resistance of the sample.

$$X_l = 2\pi fl \quad (7)$$

Where

$X_l$ : is the inductance impedance in ohm ( $\Omega$ ) units, l: is the inductance value in henry (H) units

The result also shows that the current passed through path-1 at high frequency AC current as reactance is inversely related to the frequency, so path 1 will be less impedance at high frequency. But at low AC current frequency the current will flow via path 2. Specifically

at a unique frequency, between low and high, current will flow via both paths of the circuit. So it considers representing a band pass filter [10].

## Conclusion

At low frequencies (0.3 Hz to 20 KHz) the impedance were high because of bacterial membrane capacitive effect so most current pass through extracellular matrix, as frequency increased the impedance decreased and more current began to pass through bacterial cell, at very high frequencies (40 KHz-60 KHz) the capacitive effect decreased to be neglected and the PA cell act as pure resistance and maximum current pass through it at these frequencies, while at higher frequencies ( $\geq 80$  KHz ) the current decreased again due to resistance increase, may be because of summation of both extracellular and intracellular resistance (both act as one subject), and stabilized at moderate value of current passage at 120 KHz and keep stable to maximum used frequency at 1.1 MHz.

## References

1. Asadi MR, Torkaman G (2013) Bacterial inhibition by electrical stimulation. Adv Wound Care 3: 1-7.
2. Cevc G (1990) Membrane electrostatics. Rev Biomembranes 1031: 311-382.
3. Mclaughlin S (1989) The electrostatic properties of membranes. Annu Rev Biophys Chem 18: 113-136.
4. Tsong TY (1990) Electrical modulation of membrane proteins: Enforced conformational oscillations and biological energy and signal transductions. Annu Rev Biophys Chem 19: 83-106.
5. Lee RC, Gowrishankar TR, Basch RM, Patel PK, Golan DE (1993) Cell shape-dependent rectification of surface receptor transport in a sinusoidal electric field. Biophys J 64: 44-57.
6. Mounemne Y, Tosi PR, Barhoumi R, Nicolau C (1991) Electroinsertion of xeno proteins in red blood cell membranes yields a long lived protein carrier in circulation. Biochim Biophys Acta 1066: 83-90.
7. Costerton JM, Ellis B, Lam K, Johnson F, Khoury AE (1994) Mechanism of electrical enhancement of efficacy of antibiotics in killing biofilm bacteria. Antimicrob Agents Chemother 38: 2803-2809.
8. Niebur E (2008) Electrical properties of cell membranes. Scholarpedia 3: 1-8.
9. Gur FN, Dresden TU (2012) Impedimetric detection of microorganisms using platinum nanowires. Thesis.
10. Iqbal SR (2013) Physics of bio-electrical impedance analysis: Phase angle and its application. Adv Life Sci Technol 9: 4-12.